

EARLY 1900 ARCHED WINDOW PARLOR CAR

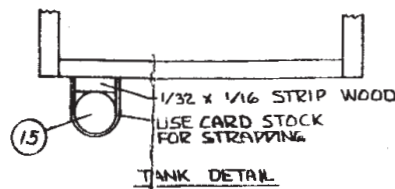
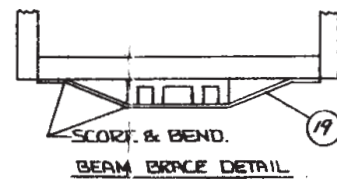
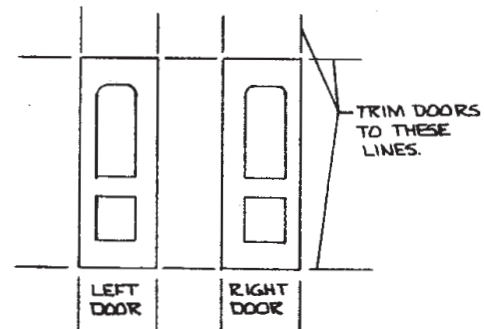
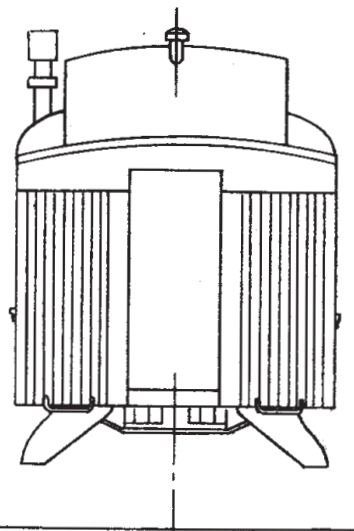
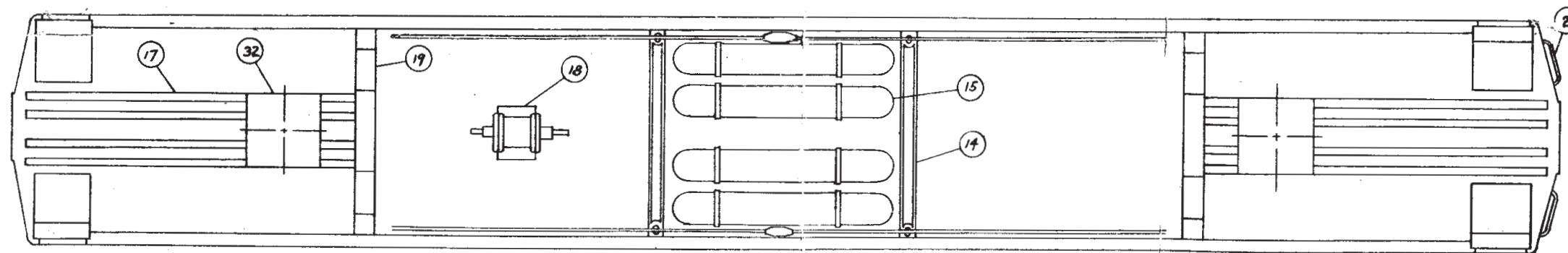
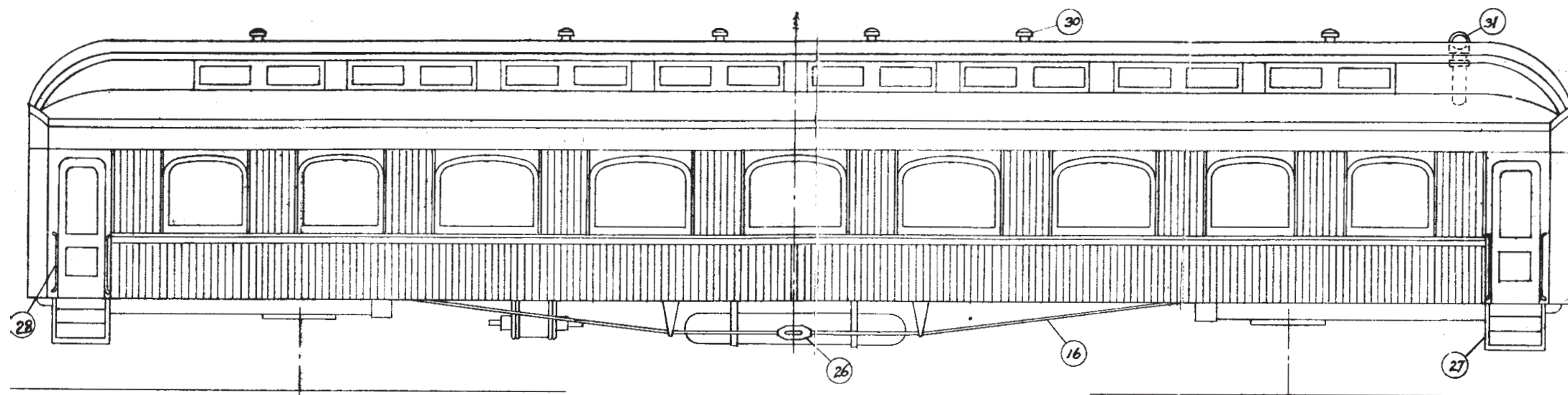

KIT NO. HO-5

La Belle Woodworking Company
Manufacturers of Model Railroad Kits

P. O. BOX 22

OCONOMOWOC, WISCONSIN

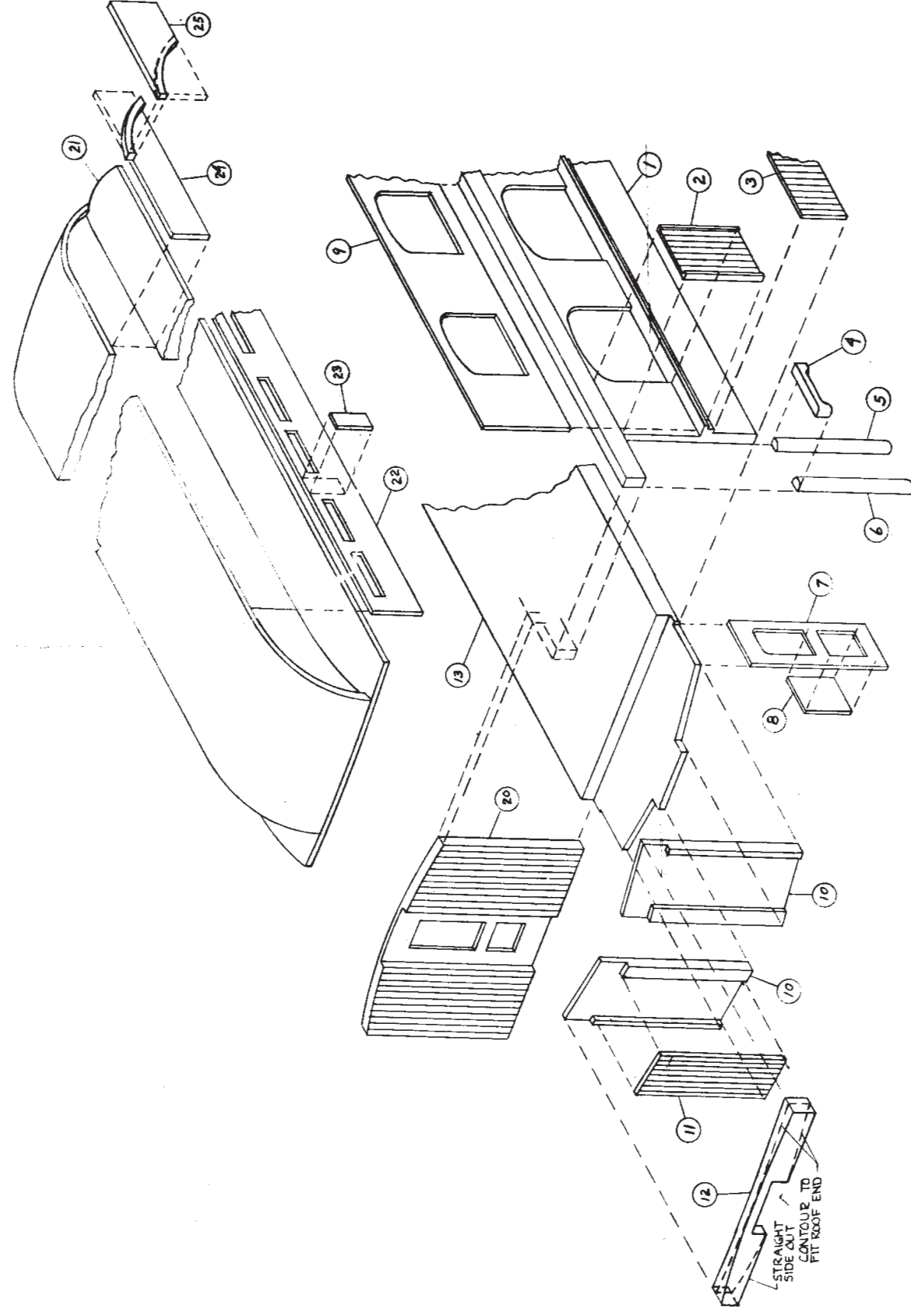

This is a basic kit of an early 1900 Parlor Car. It is not a "Quickie Kit" and therefore it is suggested that the isometric and plan drawings be studied thoroughly, also that the parts be sorted and be noted as to where they are intended to be used. It is suggested that assembly be followed by the numbers in the instructions which correspond with the numbers on the isometric and plan drawings.

These are the sub-sides (1).

Cut ten large window posts (2) to fit between bottom of letterboard and top of belt rail, and cement in place. Repeat other side.

Cement scribed siding (3) below belt rail. Trim flush with ends of sub-side (1). Cut four vestibule doors (7) to size by placing over template on plan drawing, making sure that one right and one left is made and used on its respective end. Cut panels from 1/32 by 5/16 inch stripwood (8) and cement on back of doors. Now cement doors to back of sub-sides to TOP ONLY.

Slightly round vestibule door headers (4) to match door posts (5) and (6). Cut to fit and cement in place as shown.

Next cement window sash strip (9) to back of sub-side (1) making sure margin of both sides and top of window are equal. Bottom margin of windows should now be slightly larger.

VESTIBULE END ASSEMBLY: Make up four end pieces (10) by cutting thin scribed siding (11) to fit as shown and cement in place. Now cement a completed right and left (10) to end letterboard (12) making sure that wide offset of (10) is to center.

Lay out bottom of floor (13) for position of queen posts (14), gas tanks (15), truss rods (16), beams (17), and brake cylinder (18). Cement beams (17) and 1/64 by 1/8 inch stripwood beam brace (19) in place, leaving other under-body parts off until car body is assembled.

Cement scribed bulkhead walls (20) to floor in vestibule ends as shown, making sure they are square. Now cement completed sides to floor making sure that end bulkhead walls (20) are slightly below top of sides. Now set car body aside until later.

Start to assemble roof (21) by cementing clerestory window strip (22) inside roof on each side. **IMPORTANT:** Be sure clerestory windows line up with car side windows as shown. Cut to length (23) and (24) from 1/32 by 3/16 inch stripwood, furnished, and cement in place. Now roof ends may be rounded to contour shown on plan drawing. Make template from card stock and use to check contour for correct shape. Care should be taken when sanding roof ends to size, so as not to sand off too much. Make up overhang pieces (25) for ends of roof from 1/16 by 1/2 inch stripwood, furnished, as shown and cement in place.

Apply cement to end of floor and bottom of end assembly. Temporarily place roof on car body, holding end assembly up under roof contour and against end of floor until cement has set. Remove roof and apply small fillet of cement inside where vestibule ends meet vestibule doors. After end assembly has set, apply 1/4 round (5) and 1/2 round (6) on vestibule doors as shown.

Make up and apply four gas tanks (15) as shown. Cement on queen posts (14), install truss rods (16), turnbuckles (26), brake cylinder (18) and steps (27). Make up hand rails (28) and install. Add grab irons (29). Add roof vents (brass escucheon pins) (30) and chimney (31). Car is ready for painting.

After painting, add colored acetate for clerestory windows in roof and clear acetate for lower windows.

NOTE: Position of truck centers will be determined by type and make of trucks used. Position Bolster (32) accordingly.